

# OPERATING INSTRUCTIONS

Category IV Safety Accessory



Type

**4000 Pilot Operated Relief Valve Modulating Action Type 4050M**

Application

Suitable for compressed Gas and Liquid service.

Operation

The set pressure can be varied as required by compressing or relaxing the spring in the Pilot Block using the Adjusting Screw:

Clockwise turns compress the spring increasing the set pressure.  
Anti-clockwise turns relax the spring decreasing the set pressure.

Lifting and Handling

Wooden cases should be lifted using either a Fork Lift Vehicle or a Crane with adequate Safety Approved slings applied to carry the weight, which will be evenly distributed within the case.

**Important:** All manual handling operations should be carried out in compliance with the Manual Handling Operations Regulations 1992 (SI 1992/2793) (EC Directive 90/269/EEC).

Storage

Valves with Screwed ends shall have plugs fitted in their connections to prevent ingress of dirt, etc. Flanged valves shall have their bores blanked off.

We recommend that plugs/blanks be removed immediately prior to installation.

General

1. When a new valve leaves Broady Flow Control, it has been manufactured and tested by trained and experienced personnel. When you remove a valve from your system and perform the maintenance tasks that are outlined herein, you will need proper training.

Do **not** attempt to accomplish these tasks without adequate training and understanding of the valve operation.

2. Any and all stated or implied warranties that are in effect during the purchase of a new Broady valve are null and void once the valve has been disassembled by someone other than approved Broady personnel.

3. The contents of this document are subject to change without notice.

### Safety Warning!

Discharge from outlet may be violent and must not be allowed to create a hazard to persons or property.



Testing

It is recommended that the following tests be carried out before installation of the valve: Seat tightness and set pressure.

Test Equipment

Connect valve inlet to a pressure vessel in which pressure may be raised gradually and measured by means of a precision pressure gauge.

Set Pressure Test

Check that valve starts opening at required set pressure (refer to Valve Nameplate for correct value).

Changes outside the stated tolerances must be corrected by varying the spring compression using the Adjusting Screw (13). Fig 4

To regulate the set pressure: (See Fig 4 Pilot Block)

1. Fit valve to test rig with no pressure on valve inlet
2. Remove the Locking Cover (18)
3. Adjust using Adjusting Screw (13) until the desired set pressure is achieved
4. Refit and tighten Lock Cover (18)

**Note:** For each successive set pressure check; Lock Cover (18) must be tightened.

Seat Tightness Test

After the set point lift test, test the valve for seat tightness.

The valve outlet should be fitted with an appropriately sized leakage detector (see Fig. 1) in accordance with API 527.

Raise inlet pressure to 90% of set pressure and check seat tightness for nil leakage.

Should the valve show signs of leakage, refer to table "Faults in Operation" (Fig. 2).

### Equipment For Seat Tightness Test

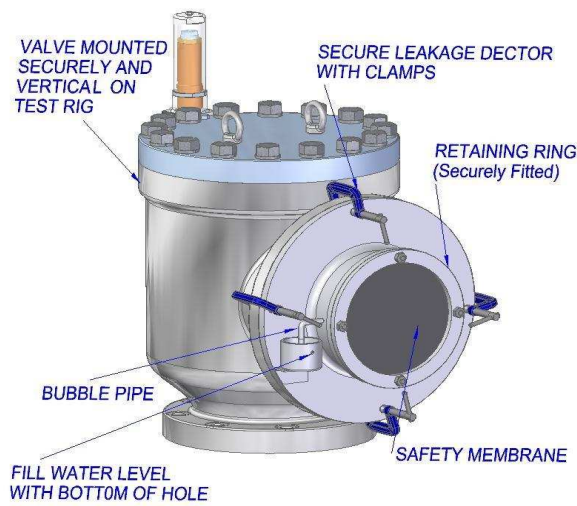

Fig 1 API 527 Compliant Leakage Detector

Installation and Commissioning

It is most important that the pipeline and valve connections be clean and free from dirt, scale, etc.



Avoid bumping or shaking valve to prevent misalignment of trim and damage to flange faces.

Fit valve in pipeline with inlet flange down and Adjusting Screw (13) in vertical position above pipeline.

It is also advisable to fit a stop valve on high-pressure side of line. The stop valve should be of full bore type so as not to restrict the flow. Use inlet and outlet pipework as short as possible and of dimensions equal to the valve connections.

Uniformly tighten fasteners securing valve connections to pipework. Secure outlet pipework in order to reduce vibration and avoid strain on the outlet.

Avoid elbows with small curvature radii on the outlet pipe: for high temperature gas and vapour discharge, use expansion joints. After valve has been installed, make it pop at least twice to allow automatic alignment of trim.



Maintenance

Regular Checks:

Check at regular intervals for signs of obvious faults.

Leakages must be repaired immediately, especially when the medium is poisonous, highly volatile or explosive.

Examine annually for signs of defect, damage or deterioration. Give special attention to contact/seating faces. If damaged, these must be re-machined.

Springs should be replaced if there is any sign of deterioration.

All parts should move freely in their respective guides.

Note: Quote the unique valve serial number when ordering spare parts.

### Safety Warning!

Before dismantling, ensure that the valve has been isolated from the pressure.



Dismantling and Reassembly Main Valve (Fig 3)

**Dismantling: Note:- Small Loose Parts in Valve**

1. Unscrew nut on the compression fittings (39 or 12) and remove Pipe (13)

2. Remove Cap Screws (10 & 33) and lift off Pilot Block assembly (3)

3. Remove O-Rings (31), unscrew Capscrews (28) and lift off Pilot Block Spacer (32)

4. Remove O-Rings (23 & 24), Plugs (22) Shuttle Valve Seat (21), Shuttle Valve (20)

5. Remove Cover Bolts and Washers (11 & 29), lift off Cover (2).

6. Remove Spring (57) if fitted and O-Ring (17)

7. Lift out Piston Lid and Piston Liner (6 & 5) from Body, remove Piston Lid (6) from Piston Liner (5)

8. Remove O-Ring (15) and Guide Rings (16) from Piston Lid (6)

9. Unscrew Counter Sink Screw(s) (18), remove O-Ring Retainer (14) and O-Ring (9) from Piston Lid (6).

10. Unscrew and remove Seat Retainer (8), lift out Seat (7) & O-Ring (19)

11. Unscrew and remove Site Test Connector assembly (37), Pick-Up Pipe Connector (36), Pick-Up Pipe (4) & O-Ring (30).

**Reassembly:**

Carry out the operations listed for disassembly in reverse, taking care to avoid damage to the seating surfaces and O-Ring seals

Clean the trim thoroughly throughout. Lubricate Adjusting Screw, Spring Carrier with graphite grease or similar



### Danger of Explosion!

Oxygen Service - Carefully degrease all components before assembling valves. Failure to do so could result in an explosion.



Dismantling and Reassembly Pilot Block (Fig 4)

**Dismantling: Note:- Small Loose Parts in Valve**

1. Unscrew and Remove Locking Cover (18), Adjusting screw(13)
2. Unscrew Cover/Spring Housing (2).
3. Lift off Spring Carrier (17), Spring (16) and Spring Carrier(15)
4. Unscrew 4 off Cap Screws (11) and lift off Distance Piece (3) with spool assembly attached.

5. With a spanner hold the top of the Nut (14) and a spanner on the hexagon of the Feed Back Piston(10),unscrew Nut (14) and Slide out the Feed Back Piston (10) from Distance Piece (3). Remove O-Ring (22,24 & 25) and Back-Up Ring (32)

6. Remove Piston (12), O-Ring (21) and Back-Up Ring (31) from Distance Piece (3)

7. Hold the Feed Back Piston(10) with spanner and unscrew Inlet Seat (4) Remove Spring (23) and O-Ring (26)

8. With a screw driver in the slot on the end of the Inner Spool (5) using a spanner, unscrew and remove the Spool Upper Seat Collar(8) and O-Ring (7)

9. Slide out Inner Spool(5) from Spool Sleeve (6) and Inner Seat (4) and remove O-Rings (20, 7, & 27,) and Back-Up Ring (37)

10. Unscrew and remove Hex Sleeve (9) from Body(1) and remove O-Rings (19)

Fig 4 Pilot Block

Item	Description	Qty
1	Body	1
2	Cover/Spring Housing	1
3	Distance Piece	1
4	Inlet Seat	1
5	Inner Spool	1
6	Spool Sleeve	1
✘	7 O-Ring	2
8	Spool Upp Seat Collar	1
9	Hex Sleeve	1
10	Feed Back Piston	1
11	Sock Head Cap Screw	4
12	Piston	1
13	Adjusting Screw	1
14	Nut	1
15	Spring Carrier Lower	1
16	Spring	1
17	Upper Spring Carrier	1
18	Locking Cover	1
✘	19 O-Ring	2
✘	20 O-Ring	1
✘	21 O-Ring	1
✘	20 O-Ring	1
✘	22 O-Ring	1
✘	24 O-Ring	1
✘	25 O-Ring	1
✘	26 O-Ring	1
✘	27 O-Ring	1
✘	31 Back-Up Ring	1
✘	32 Back-Up Ring	1
✘	36 Vent Plug	1
37	Spindle	1
✘	38 Joint	1
39	Plug	1

✘ Recommended Spare Parts.

**Reassembly:**

Carry out the operations listed for disassembly in reverse, taking care to avoid damage to the seating surfaces and O-Ring seals

Clean the trim thoroughly throughout.



Dismantling and Reassembly Site Test Connector (See Fig 5)

**Dismantling: Note:- Small Loose Parts in Valve**

1. Remove Locking Pin (7)
2. Unscrew Seat (2)
3. Lift out Lid (3) and remove O-Rings (4 & 5)

**Reassembly:**

Carry out the operations listed for disassembly in reverse, taking care to avoid damage to the seating surfaces and O-Ring seals

Clean the trim thoroughly throughout.

Fig 5 Site Test Connector

Item	Description	Qty
1	Body	1
2	Seat Adaptor	1
3	Lid	1
✘	4 O-Ring	1
✘	5 O-Ring	1
6	Blanking Plug	1
✘	7 Spring Pin	1

✘ Recommended Spare Parts. All Flange rating

**OPERATING INSTRUCTIONS**

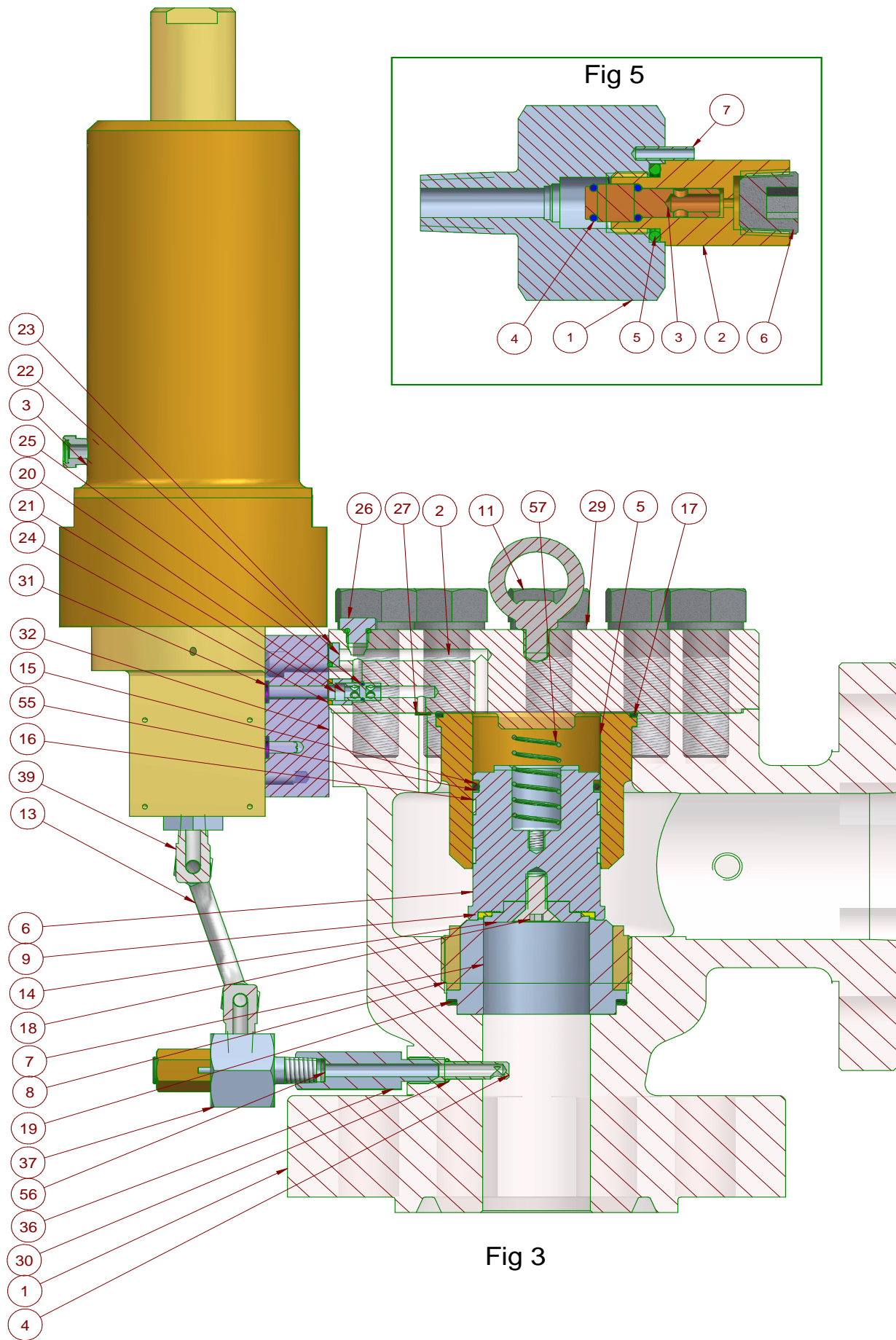

**Fig 3**

**Fig. 2 - Faults in Operation**

FAULT	CAUSES	SOLUTIONS
Leakage	(1) Presence of foreign matter between seat and disc	(1) Discharge valve once or twice consecutively. Should leakage continue, disassemble valve and clean trim.
	(2) Scratching or pitting on seat surface	(2) Disassemble valve, grind and lap seat.
	(3) Valve not mounted vertically.	(3) Correct installation.
	(4) Seat O-Ring damaged	(4) Replace O-Ring
Discharge at incorrect pressure	(1) Loosening of Lock Nut on Spring Adjusting Screw. (18)	(1) Tighten lock nut after re-calibrating the valve.
	(4) Poor trim alignment.	(4) Discharge the valve 2 or 3 times to allow self-alignment of the trim.

**Fig 3 Pilot Main Body Assembly**

Item	Description	Qty
1	Body	1
2	Cover	1
3	Modulating Action Pilot	1
4	Pick-Up Pipe	1
5	Piston Liner	1
6	Piston Lid	1
7	Seat	1
8	Seat Retainer	1
9	O-Ring	1
10	Sock Head Capscrew	4
11	Bolts	Various
12	Compression Fitting	1
13	Pipe	1
14	O-Ring Retainer	1
15	O-Ring	1
15B	Back Up Ring for 900 to 2500 ANSI	1
16	Guide Ring	2
17	O-Ring	1
18	Counter Sink Screw	Various
19	O-Ring	1
20	Shuttle Valve	1
21	Shuttle Valve Seat	1
22	Blanking Plug	1
23	O-Ring	3
24	O-Ring	1
25	O-Ring	1
26	Plug	1
27	O-Ring	1
28	Sock Head Capscrew	2
29	Spring Washer	Various
30	O-Ring	1
31	O-Ring	1
32	Pilot Block Spacer	1
33	Sock Head Capscrew	2
34	Plug	2
35	Modulating Plug	1
36	Pick Up Pipe Connector	1
37	Site Test Connector	1
39	90° Compression Fitting	1
56	Filter	1
57	Spring	1

✳ Recommended Spare Parts.

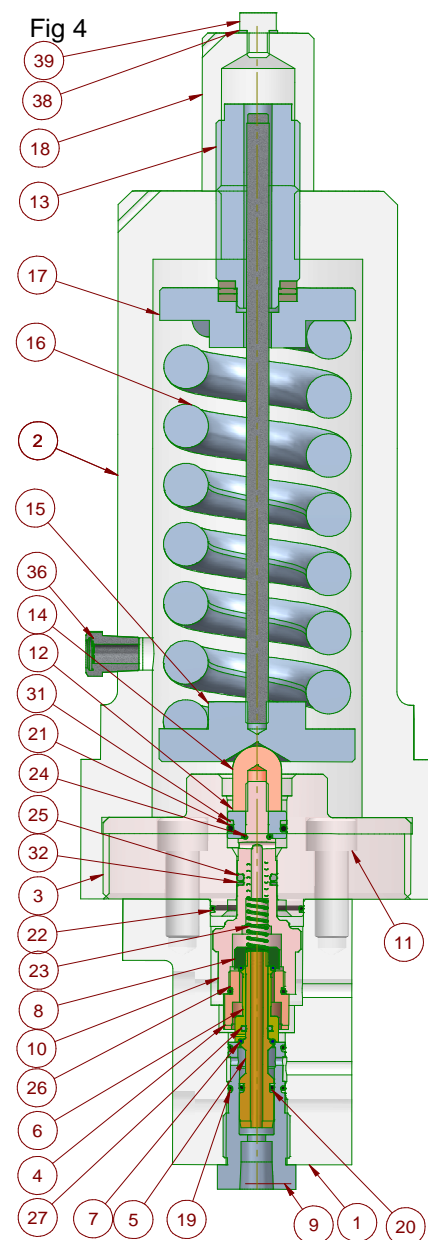

**Fig 4**